

## 01 Product Overview



CESIPC G-Series 10-inch full stainless steel industrial panel PC is designed for small equipment and local workstation applications in wet washdown areas of food, dairy, and pharmaceutical industries. The whole unit features SUS304/316 stainless steel construction with IP67/IP69K dual protection, capable of withstanding high-temperature, high-pressure hot water and chemical cleaning agents, allowing exposed installation without an enclosure. The compact 10-inch size is suitable for space-constrained equipment integration, supports industrial-grade touch and multi-platform processors, providing a reliable solution for small HMI and equipment control in wet washdown areas.



### Features



### Certifications



## Key Features

- ★ Display: 10-inch 4:3 industrial-grade XGA TFT LED LCD, resolution 1024x768, 16.2M colors, brightness 350 cd/m<sup>2</sup>;
- ★ Touch: Projected capacitive P-CAP 10-point touch, supports glove operation, whole unit IP67/IP69K protection;
- ★ Core: Intel® Celeron® J1900 embedded quad-core processor, cost-effective, stable and reliable;
- ★ Ethernet: Dual Gigabit Ethernet ports for high-speed and stable industrial network communication;
- ★ Rich I/O: 2 USB 2.0, 2 RS232, 1 Gigabit Ethernet port;
- ★ Expansion: Supports 1x Mini PCIe Wi-Fi module expansion (optional Wi-Fi, Bluetooth, 4G/5G communication modules);
- ★ Technology: BlockCore™ modular design for scalability and high maintainability;
- ★ Reliability: FANLESS fanless cooling, reliable and stable, maintenance-free design;
- ★ Supports CESIPC SafeCore™ technology to prevent power-off damage and ensure long-term stable system operation;
- ★ Construction: Rugged 304/316 stainless steel housing, industrial-grade robust body, whole unit IP67/IP69K protection.

## 02 Product Images



## 03 I/O Interface



## 04 Technical Specifications

### • Touch & Display

Parameter	Specification
Display Size	10" (4:3)
Display Type	XGA TFT LED LCD
Resolution	1024 × 768
Color Depth	16.2M
Brightness	350 cd/m <sup>2</sup>
Contrast Ratio	500:1
Backlight Life	50,000 hrs
Touch Method	Projected capacitive touch (P-CAP), 10-point
Touch Protection	IP67 (whole unit)

• Core Hardware

Parameter	Specification
Processor	Intel® Celeron® J1900
Cores	4
Threads	4
Frequency	2.0~2.42 GHz
Cache	2 MB L2 Cache
TDP	10W
Graphics	Intel HD Graphics
Memory	DDR3L 4~8 GB
Storage	1x mSATA SSD

• I/O Interfaces

Parameter	Specification
USB 2.0	2
RS-232	1
RS-485	1
Gigabit Ethernet	1 x LAN
Audio	3.5mm TRRS
Wi-Fi (Optional)	Dual-band 2.4G/5G wireless card
4G/5G (Optional)	/

• Power Input

Parameter	Specification
Power Connector	1x 3-pin pluggable terminal block, supports 9~36V DC wide-range input
ATX Switch	1x ATX power switch
Boot Mode	AT/ATX mode switch (built-in)

• Product Attributes

Parameter	Specification
Dimensions	278(W)*225.4(D)*57.8(H)mm
Weight	4 KG net weight
Chassis Material	304/316 Stainless Steel
Mechanical Structure	Sheet metal structure
Mounting	Panel mount / VESA 100x100 wall mount
Reset Switch	1x Reset switch
TPM	TPM 2.0
Watchdog Timer	Hardware watchdog supported
MTBF	60,000 hrs

• Operating Environment

Parameter	Specification
Operating Temp.	0~60°C (wide-temp -40~80°C optional)
Storage Temp.	-10~70°C (wide-temp -40~80°C optional)
Relative Humidity	10%~90%, non-condensing
EMC	CE, FCC (EN 55032 & EN 55035)
EMC Harmonics	EN IEC 61000-3-2

• Operating System

Parameter	Specification
Windows	Windows 7 / Windows 10 / Windows 11
Linux	Ubuntu 16.04 / 18.04 / 20.04 / 22.04

• Certifications & Compliance

Parameter	Specification
Factory Cert.	ISO9001: 2015
BIOS Customization	BIOS / Boot LOGO / OEM

## 05 Mechanical Dimensions

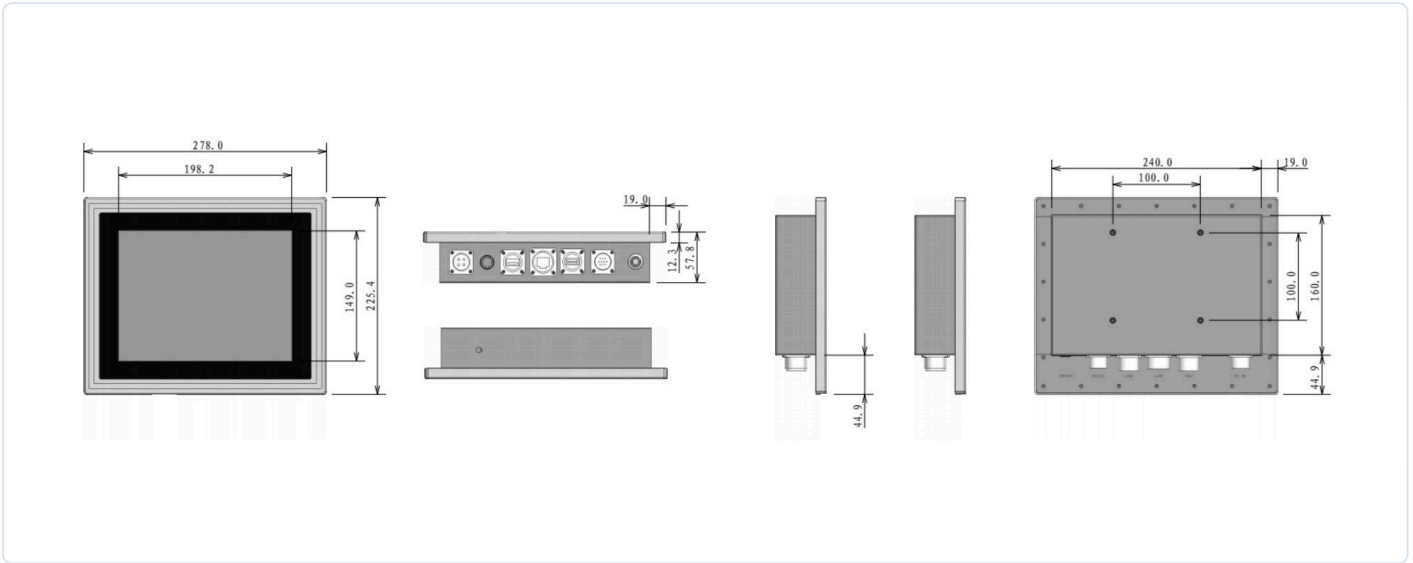

## 06 Applications



Industrial Equipment Control



Data Acquisition



Transportation



Energy

## 07 Ordering Information

NO.	Model	Part No.	Processor	Memory	Storage
1	WPC-S1062A-G	C20.01.01.001	Intel® Celeron® J1900, 10" P-CAP	4GB DDR3	SSD 128GB
2	WPC-S1062A-G	C20.01.01.002	Intel® Celeron® J1900, 10" P-CAP	8GB DDR3	SSD 128GB

※ Note: Due to market fluctuations, CPU models, memory, hard drives and other key chips may change. Please consult our sales team for details.

※ Specifications subject to change without notice. Data measured under standard test conditions.

For customization or support, contact CESIPC: 0755-85286060 · sales@cesipc.com · www.cesipc.cn

© 2026 Cloud Embedded Technology Co., Ltd. (CESIPC) · All Rights Reserved